

CERTIFYING MULTIMODE FIBER CHANNEL LINKS FOR 10 Gb/s ETHERNET

Rick Pimpinella and Al Brunsting
Fiber Research Department

Panduit Corp., Orland Park, IL 60427

Abstract – PANDUIT has developed new test methods for qualifying multimode fiber (MMF) channel links at the high-speed data rate of 10 Gb/s. Within the context of the applicable standards these methods are summarized and applied to three practical examples. The results show how these MMF channel links are affected by fiber length and fiber type.

1. INTRODUCTION

The continuing drive for higher bandwidth is evident in most connectivity applications that operate in the business, education, and government arenas. LAN backbones and data centers are being deployed or retrofitted, at least in part, to 10 Giga-bits/sec (Gb/s) optical links so that higher data rates might be delivered to an increasing number of desktops.

Specifications and standards for 10Gb/s data rates (such as IEEE 802.3ae for 10Gb/s Ethernet) have been approved that focus on performance and low cost (see Fig. 1). Optical sources utilize vertical cavity surface emitting lasers (VCSELs) to achieve cost effective operation at 10Gb/s in the 850nm window. A popular fiber type for this application is a laser optimized OM3 multimode fiber (MMF) with a (50/125) μm (core/cladding) diameter that provides low cost and the required performance. (See Appendix.)

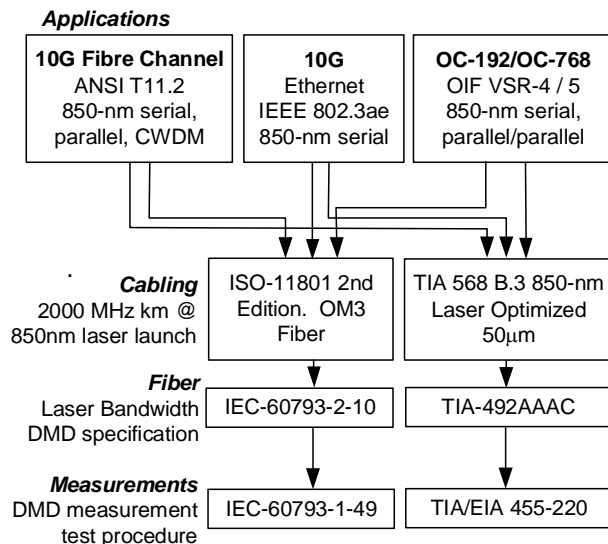

Figure 1. 10-Gigabit Multimode Standards.

Standards, such as the IEEE802.3ae, typically specify the maximum channel link loss as a primary link parameter. Although measured installed link loss is an important parameter, the link loss is not an indicator of whether or not a fiber is capable of supporting 10Gb/s error free transmission. The most precise measure of channel performance is bit error rate (BER) testing. BER is the number of bit errors per unit time compared to the total number of bits transmitted per unit time.

Error free propagation of bits of data through the fiber link is the ultimate design goal of the MMF and connectors in that optical link. There are two basic measures of this transport performance: (1) the data rate of the bits passing through the fiber (in bits/sec) and (2) BER. Data rates are standard and can readily be determined. BER, however, is challenging to measure at 10Gb/s. In this paper we will focus on how PANDUIT measures BER at data rates of 10 Gb/s and how BER is used to determine the quality of optical channel links.

2. CERTIFYING OPTICAL LINKS

To certify optical links and patch cords for 10Gb/s data rates, a test method that accurately emulates a 10Gb/s optical link at 850nm (10GBASE-S) was developed. The method employs a Bit Error Rate Test (BERT) system that simulates the optical transmitter and receiver and measures the link performance in terms of BER. Where, a BER of 10^{-12} indicates that 1 bit is in error for every 10^{12} bits transmitted. The test system is configured to meet 10GBASE-S transceiver specifications and the fiber under test is verified to meet system performance requirements per IEEE 802.3ae. The BERT is programmed to take and save repetitive measurements over extended periods of time. By eliminating unnecessary connectors in the system and assuring that connectors are blemish free, have optimum end-faces geometry and low insertion loss, optical interference effects due to modal noise induced by connector interfaces are minimized.

The fiber under test is connected to the BERT using two laser-optimized, 2000MHz \cdot km patch cords. Cladding modes are filtered using a conventional 1-inch mandrel rap. A strict cleaning procedure was implemented to help achieve stable performance. The Bit Error Rate Test configuration is shown in Figure 2.

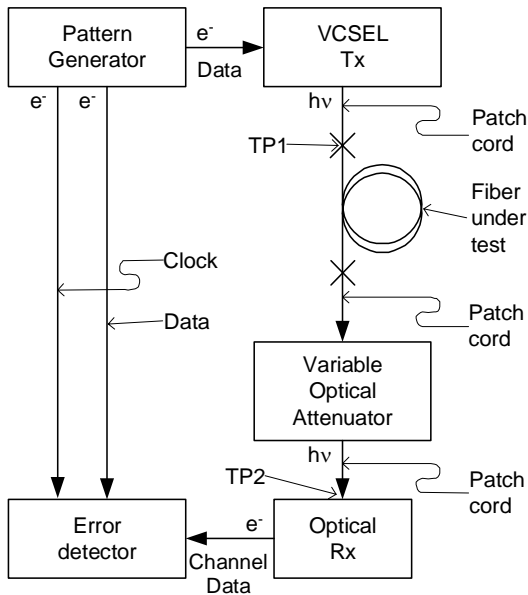

Figure 2. Set-up to measure bit error rates. (Optical, Electrical) paths are indicated by ($h\nu$, e^-). Test points (1, 2) are indicated by (TP1, TP2).

A pattern generator drives a VCSEL transmitter with a Pseudo Random Binary Sequence (PRBS) of $2^{31}-1$ bits. The output power levels of the transmitted signal must be carefully controlled to emulate a valid output launch pulse compliant to IEEE 802.3ae. The required performance for a 10GbE system as defined by IEEE 802.3ae, is a BER of 10^{-12} for a minimum receiver power of -9.9dBm . The performance of the fiber under test is characterized by measuring the Bit Error Rate as a function of receiver average power. See Figure 3. The input power to the optical receiver is incrementally controlled by means of an

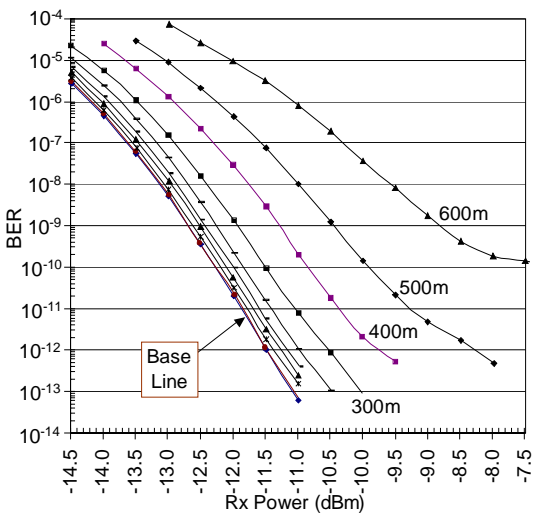

Figure 3. Performance of fiber type A as determined by BER vs. received optical power (dBm).

external variable optical attenuator (VOA). For 10GBASE-S compliance we certify that our $50/125\mu\text{m}$ MMF under test, having a modal bandwidth of $2000\text{MHz}\cdot\text{km}$, will perform for lengths up to 300m.

3. ALTERNATIVE TEST METHODS

There are two alternative measurements used to specify the performance of optical fibers, summarized in this section: (1) differential mode delay (DMD) and (2) calculated effective modal bandwidth (EMBc). For both measurements the requirements for the light source, launch system, detection system, and test samples are specified in TIA/EIA-455-220.

DMD. In this measurement constrained pulses of light are launched into the MMF under test for increasing offsets from center launch (see Figure 4). The optical pulses simulate digital information (zero and one bits). Transmitter rise and fall times are controlled. The launched light forms a small spot size on the input side of the MMF under test, resulting in the excitation of one (or only a few) mode group(s) in the MMF. As a given pulse propagates through the MMF, it undergoes delay and its shape changes. This is then measured by fast receiver and detection electronics. The illuminating spot is carefully positioned relative to the axis of the MMF. At different axial positions, the launched pulse train undergoes different delay times and may change shape due to dispersion, mode coupling and fiber length. Analysis of these delays and shape changes yields information about the bandwidth of the fiber.

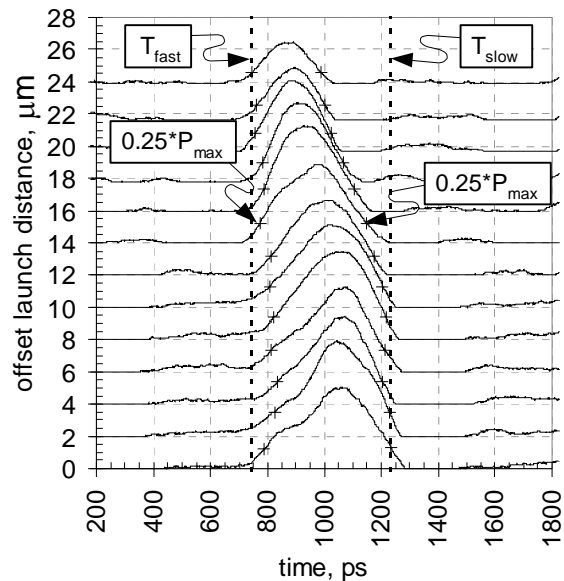

Figure 4. Pulses from this DMD measurement are offset by $2\mu\text{m}$ from each other relative to the center of the MMF that is under test. (T_{fast} , T_{slow}) are the (fastest, slowest) of all the $0.25 \cdot P_{\text{max}}$ values where P_{max} is pulse maximum.

Referring to Figure 4, $DMD = (T_{SLOW} - T_{FAST}) - \Delta T_{REF}$, where ΔT_{REF} is the launch pulse width. When all the delay times are similar and the pulse shapes do not change much, DMD is small and the bandwidth is large.

EMBc (effective modal bandwidth calculated). Light from 10 Gb/s transmitters must meet certain spatial (Encircled Flux) requirements. A weighting scheme, simulating the spatial characteristics of a set of appropriate 10 Gb/s transmitters, is used in this standard. Signal pulses (in the time domain) from the DMD measurements are weighted and converted to the frequency domain using a Fourier transform. The effective modal bandwidth is calculated from the Fourier transform, using the worst-case transmitter in the set. If the fiber has a reduced bandwidth, then there will be fewer high frequency components in transformed pulses.

It is not clear how accurately either method can be used to determine bandwidth since stress in the cabled fiber and other extraneous factors are not considered. For DMD there are measurement uncertainties such as location of the axis of the MMF under test, the end faces must be perpendicular to the fiber axis, pulse measurement error, and the end face of the launch fiber must be close to (but not touching) the end face of the MMF. Also, MMF eccentricities and departures from circularity can contribute to inaccuracies which are not directly included in DMD.

For EMBc, all the uncertainties for DMD apply plus measurements in the time domain such as temporal filtering of the pulses, determination of a zero, signal level for the pulses, and aliasing.

In contrast to these two techniques, a BER measurement is much closer to how the fiber link is actually used. Pulses are launched into the optical link under test that are representative of a practical link. Individual bit errors are counted and recorded. This is how the optical link will actually be used and how the BER is specified for the application.

Optical and electrical transceivers have been evaluated by measuring BER for decades so that this method has been validated as a standard method for performance evaluation of signal propagation.

4. EXAMPLES OF THE PANDUIT APPROACH

BER as a function of length. The ability of MMF to support data rates of 10Gb/s depends on length, fiber refractive index profile, as well as other factors. In Fig. 3, we plot the performance of fiber type A in terms of BER (log scale) vs. received optical power (in units of dBm) for fiber lengths of 50, 100, 150, 200, 250, 300, 400, 500 and 600 meters.

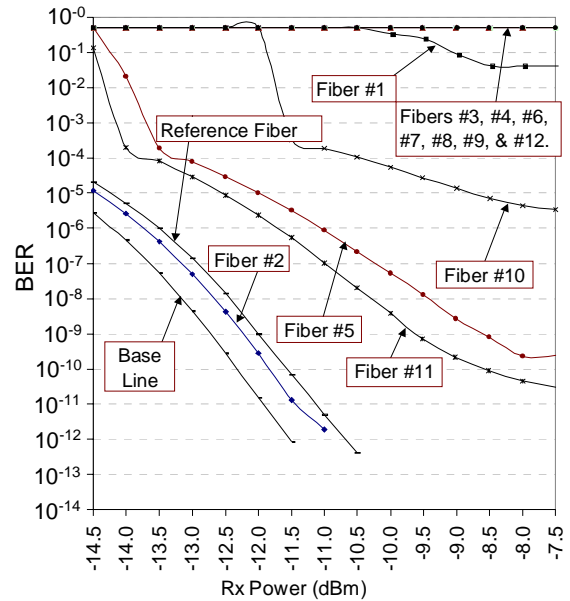

Figure 5. Performance of 12 fibers within one ribbon cable as determined by BER vs. received optical power (dBm).

Analysis of the data shows that this fiber supports 10Gb/s data transmission for distances of 300 meters or less. We see in Figure 3 that for the 300m length, we measure a bit error rate of 10⁻¹² for a receiver power of -10.5dBm. The requirement for measured receiver power is to not exceed a minimum specified optical power of -9.9dBm (it is important to note that the 10Gb/s optical test signal simulates minimum specified values). Therefore, this fiber passes the IEEE 802.3ae Physical Medium Dependent (PMD) sub-layer requirements, provided the optical receiver and transmitter in the 10GBASE-S system meet specification.

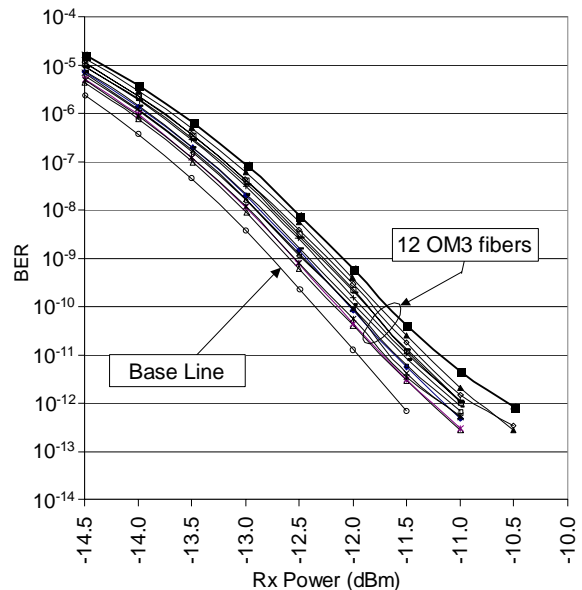

Figure 6. Qualification of 12 OM3 fibers within one ribbon cable as determined by BER vs. received optical power (dBm).

At lengths above 300m, the bottom right portions of the curves become more horizontal. As the fiber length increases, this effect is more pronounced. At some length above 600m, we may expect that no amount of received power will lower the BER. This is called the BER floor.

BERT to qualify each fiber within a single ribbon cable. *PANDUIT* received ribbon cable consisting of 12 MMFs. The cable was intended for a product that would support data rates of 10 Gb/s and would be compliant with the IEEE 802.3ae specification. The vendor classified each of the MMFs as being laser optimized (OM3). Each fiber was tested using the *PANDUIT* BERT system.

Analysis of the results (Figure 5) shows that 11 out of 12 MMFs fail BER testing and do not meet OM3 performance requirements. *PANDUIT* testing results and conclusions were shared with the vendor who thoroughly examined the records of the MMFs in this ribbon and concluded that a manufacturing error was made and the fibers were not OM3 fibers.

Qualification of OM3 MMF. Similar to the example above 12 MMF's were formed into a ribbon cable by another vendor. As before, this vendor classified each of the MMFs to be OM3. Using the same test methods as were used in both Figures 3 & 5, test results showed that each of the MMFs were compliant to IEEE 802.3ae (see Figure 6). Each fiber was qualified to meet OM3 performance levels. We have also found that the cabling process affects 10 Gb/s fiber. BER measurements can be used effectively to evaluate the final product, fiber and the associated cable.

5. CONCLUSIONS

Three methods for qualification of MMF links were summarized (DMD, EMBc and BERT) together with three practical examples of how the *PANDUIT* test method can be applied. In one example it was shown how performance (BER) changes with MMF length. Given the channel insertion loss is within specified limits, the maximum fiber length depends on fiber bandwidth. In the other two practical examples, it was shown how specific MMFs in ribbon cable could be certified for 10Gb/s data rates. Pertaining to the studies conducted within this paper, applicable specifications and standards were reviewed and it has been shown that *PANDUIT* procedures are consistent with these standards (IEEE 802.3ae, FOTP 220 and TIA-492AAAC-A).

Of the three methods of qualification, *PANDUIT* uses BERT, which is closest to how the MMF links are actually used in the field. BER detection is the most realistic method and the least susceptible to measurement uncertainties.

APPENDIX

In Table A, optical fiber classification, type, and minimum modal bandwidth are given. "Overfill Launch" refers to an optical source that is a light emitting diode (LED) which excites all the available modes in the MMF.

Table A. Summary of different types of MMFs.

Optical Fiber Type		Minimum Modal Bandwidth, MHz•km.		
		Overfill Launch (OFL) Bandwidth		Effective Laser Launch Bandwidth
Classification	Core Diameter, μm	850nm	1300nm	850nm
OM1 ¹	50 or 62.5	200	500	Not specified
OM2 ¹	50 or 62.5	500	500	Not specified
OM3 ¹	50	1500	500	2000
A1a ²	50	500	500	Not specified
A1b ²	62.5	160 or 200 ³	500	Not specified

Notes:

1. Source: International Standard ISO/IEC 11801, Second edition 2002-09, Table 27, page 62.
2. Source: International Standard CEI/IEC 60793-2-10, First edition 2002-03, Annex A, B, & D.
3. From source 2: "Value recommended by ISO/IEC 11801 with the following: Fibres with other normalized bandwidth cells can be used, proportionally changing the allowed link length."