

# OPEN RACK APPROACHES FOR MAXIMIZING THE EFFICIENCY OF EQUIPMENT IN A COLD- AISLE/HOT-AISLE DATA CENTER ENVIRONMENT

By: Lars Larsen  
Product Manager - Physical Support  
Ortronics/Legrand



# WHITE PAPER

## Open rack approaches for maximizing the efficiency of equipment in a cold-aisle/hot-aisle data center environment

### Executive Summary

It is a commonly held belief by IT and facilities managers that energy efficiency solutions in the data center can be costly. While it is critical to have an overall strategy for data center efficiency that includes some capital expenditures, there are many initiatives that can be implemented immediately and without significant cost impact. As long as these are not in conflict with the overall strategy, these initiatives have the potential to add up to significant energy savings.

An effective first step in improving the energy efficiency of a data center is the implementation of effective cable management practices. An advanced approach to cable management in the data center can reduce power and cooling costs, while also enhancing network performance. The positive effect of this approach is supported with data from Tileflow software, a simulation tool for airflow and temperature distribution in data centers. This paper will focus on cable management solutions for data centers utilizing side-to-side vented equipment. A subsequent paper will be developed to address newer switches with front-to-rear cooling.

### Background

With consolidation, virtualization, and the increased server densities found in today's data centers, the heat generated by server and computer networking equipment is creating new concerns over efficient cooling and power management. Cooling comprises an estimated 50% of the power required to operate a data center. Addressing the burden factor in the data center is fast becoming a hot issue for facilities managers. The burden factor is the ratio between the amount of power it takes to run a piece of equipment in the data center and the amount of power it takes to cool that same piece(s) of equipment. A rack loaded with equipment that generated only 2 to 3 kW of heat a few years ago is today requiring up to 50 kW of power. Since heat remains the most common reason for equipment failures, proper cooling is essential to maintaining reliable operation.

Today's electronic data processing and memory storage equipment contains internal thermal sensors that can slow down the processing speed (and thus generate less heat). Consequently, excessive heat can seriously disrupt efficient operations and increase the likelihood of network downtime.

Cooling and power remain the top two concerns with IT administrators. In a poll at Gartner's IT Infrastructure, Operations and Management Summit 2007, attendees indicated that the greatest facility problems with data centers are insufficient cooling and insufficient power. In fact, the overwhelming majority said they will expand/upgrade, relocate or renovate their facility over the next year to accommodate power and cooling needs.

# BUILDING A SOLID FOUNDATION

## The Physical Support Layer

As is the case with creating most structures of any complexity, a solid foundation is critical for optimizing network performance. This is illustrated in the International Standard Organization’s Open System Interconnect (ISO/OSI) model, which defines seven network layers, the most basic of which is Layer 1 (Physical Layer).

The physical layer is defined as the cable or physical medium itself, e.g., thinnet, thicknet, unshielded twisted pairs (UTP). However, it does not include Physical Support (racks, cabinets and cable management). Ortronics/Legrand proposes a new perspective to the concept of networking by

establishing “Layer 0” of the OSI model and defining it as Physical Support, thus adding a new level of stability to the network (as illustrated in Figure 1).

This concept is further supported in the Cisco white paper titled Cisco Energy Efficient Data Center Solutions and Best Practices:

“For IT professionals, the rack should be the primary building block for power and cooling planning. Starting with the rack gives the planner a higher level of control when considering the peripheral supporting infrastructure and adjacent affects of IT infrastructure.”

**Figure 1: A New Layer in the OSI Model**

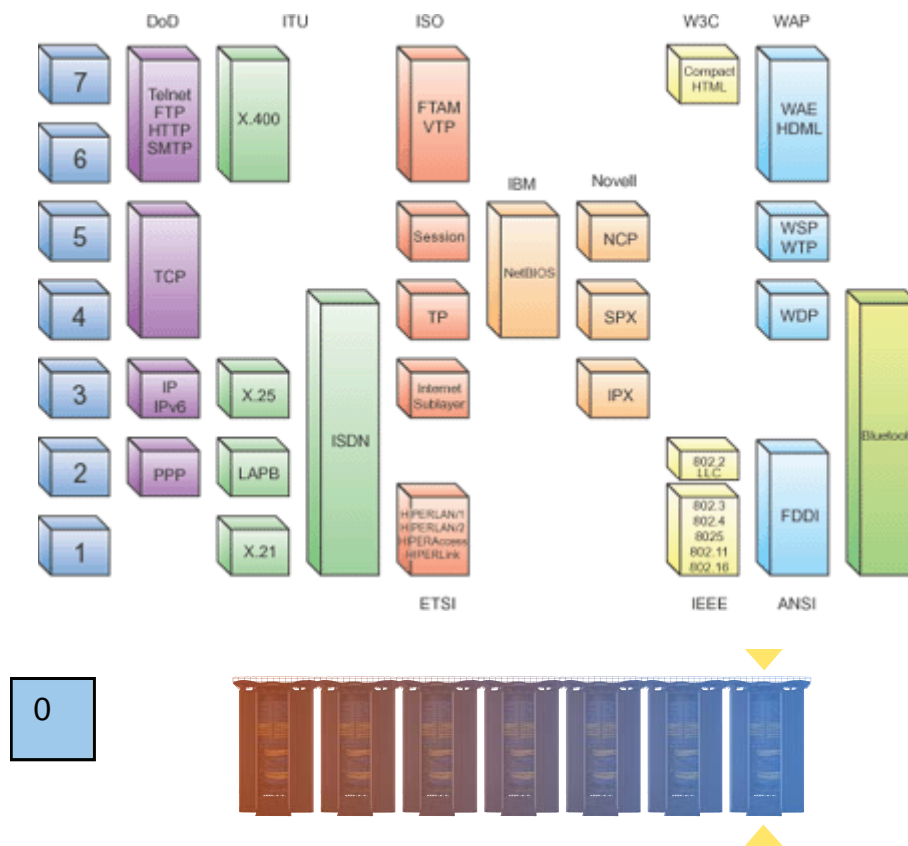

<sup>1</sup> Indiana University Unix Systems Support Group, [http://www.ussg.iu.edu/usail/network/nfs/network\\_layers.html](http://www.ussg.iu.edu/usail/network/nfs/network_layers.html)

<sup>2</sup> Cisco Systems, Inc., “Cisco Energy Efficient Data Center Solutions and Best Practices” white paper, 2007.

# THE HOT AND COLD OF COOLING

The preferred method of cooling in today's computer rooms is the cold-aisle/hot-aisle approach, as shown in Figure 2. In a typical configuration, cold air is delivered via the under-floor plenum up into the room through perforated floor tiles located in the designated cold aisle. This cold air is then drawn through the rack-mounted network equipment air intake, where it absorbs the heat generated by the electronic equipment, and exits out the equipment exhaust with the intent of ending up in the back of the rack in the hot aisle. This "hot-aisle" warm air is then exhausted from the room for recirculation through the cooling system via the overhead plenum.

In the cold-aisle/hot-aisle configuration, racks or cabinets are positioned to face each other, with front sides facing the cold aisle and back sides facing the hot aisle. It is important that the cold aisles remain segregated from the hot aisles. Efforts must be made so air from the two aisles does not mix. Ideally, the only air flow taking place between hot and cold aisles is through the cooling fans of the equipment. Allowing warmed air to return to the cold aisle raises the temperature of the equipment's intake air and minimizes the efficiencies of the equipment.

**Figure 2:** Cold-aisle and hot-aisle cooling

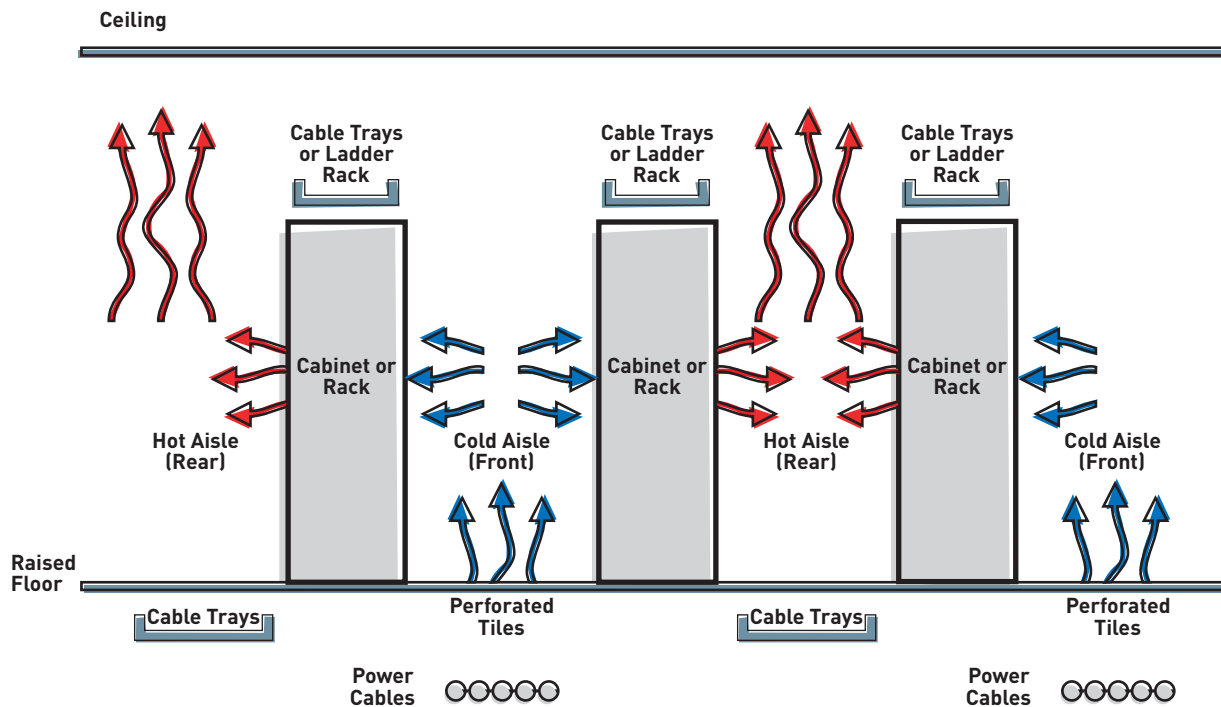

# MOVING THE COLD-AISLE BOUNDARY

The traditional method of cooling data storage equipment has typically drawn air in the front (from the cold aisle) and exhausted it out the back (to the hot aisle) through the use of fans. Some newer equipment draws air from the bottom and exhausts it through the sides or top. Other equipment draws through one side and exits from the other. This is done in order to allow more room for cabling, connectivity, and cable management at the front and rear of the equipment where easy access is required for maintenance and cross connections.

As part of an overall data center efficiency strategy, there are immediate steps that can be taken to improve the efficiency in this cold-aisle/hot-aisle environment.

1. The airflow of the equipment should not be restricted, whether that airflow is side-to-side or front-to-back. Open racks with features for airflow, such as perforated sides, can significantly reduce equipment energy consumption.
2. When using equipment that does not draw air from front to back, a secondary system can aid with ensuring that the intake air is drawn from the cold aisle and hot air is directed toward the hot aisle. For example, in an environment with side-to-side vented equipment, it is necessary to redirect the airflow so it flows from the cold aisle (front) to the hot aisle (rear). Baffles can be deployed to control the airflow on a switch such as the Cisco Catalyst 6513, where the intake is on the right side and the exhaust is located on the left side of the switch. The baffles ensure the intake air is drawn from the cold aisle and direct the exhaust to the hot aisle. The absence of such an approach with a row of racks with side-to-side cooling allows the exhaust of switch 1 to

be the intake of switch 2, which further heats the air before exhausting it into switch 3 intake. Each switch is getting less cooling as you go down the row, even though the cold aisle air temperature is appropriate for switch 1.

3. Proper rack selection will move the cold-aisle/hot-aisle boundary as far back on the equipment as possible. If you consider the row of racks as the boundary between hot and cold aisles, the back of the rack is exposed to the hot aisle. With a standard 3-inch EIA rack, the hot air surrounds all but 3 inches of the equipment. Instead of a standard 3-inch deep EIA rack where most of the switch is exposed to the hot aisle, consider a deep channel rack where only the exhaust surfaces of the equipment are exposed to the hot aisle.
4. Blanking panels should be used to prevent the unintended flow of air through the rack. The use of blanking panels on the rear of the deep channel rack will prevent the ambient air surrounding the switch from being heated by the air already in the hot aisle. The same approach also improves the cooling of servers and other front-to-back airflow equipment. Surrounding these surfaces with cooler air supplements the fan-assisted cooling at little or no additional cost. An added benefit to this method is that the network distribution cables are not exposed to the hot aisle, thereby keeping them cooler as well. Tests have shown that an increase in conductor temperature can increase copper conductor resistance and reduce transmission performance. Cooler cables perform better, which can significantly reduce bit-rate errors. Reducing the bit errors will reduce retransmissions required for Ethernet CSMA/CD protocols, which reduce the power consumption of the equipment.

## PROOF IS IN THE DATA

A series of tests was conducted using Tileflow computer modeling software to show the thermal effect of various rack configurations within a data center environment. The objective of this series of tests is to prove that with proper rack, cable, and airflow management, the average room temperature can be lowered within the data center, thus providing many benefits. These benefits include reduced power usage requirements for cooling the equipment, savings in energy costs, less downtime due to fewer equipment failures, lower equipment maintenance costs and better overall network performance.

A set of three (3) racks was utilized to perform this thermal simulation in a hot aisle/cold aisle environment within a data center. In this set of experiments, a Cisco Catalyst 6509 switch was used in each rack. The rest of the rack was assumed to have no airflow due to cables and blanking panels. With this set up, Ortronics' Mighty Mo 10 racks were compared to standard EIA racks loaded with similar equipment.

Figure 3 shows three Mighty Mo 10 racks loaded with Cisco Catalyst 6509 switches with side-to-side air venting. Figure 5 shows a similar configuration in a standard EIA rack. Figures 4 and 6 show the thermal imaging plots and airflow for both configurations, respectively.

The imaging plot in Figure 4, with the Ortronics Mighty Mo 10 system, shows the temperature at the intake of the Cisco Catalyst 6509 switches to be at or below 55 degrees F. As the air goes through the equipment, the air is directed towards the hot aisle, blocking it from mixing in with the cold air. The temperature of the exhaust air in the hot aisle does not rise above 85 degrees F, which will reduce the amount of energy needed to cool the air in the data center. In a similar set up with standard EIA racks (Figure 6), the warmer air from the hot aisle mixes in with the cold intake air, thus raising the temperature of the intake air for the last rack in the row to above 80 degrees F. The effect is that the exhaust air temperature is much higher (>95 degrees F) at the outlet of the third switch in the row. The higher temperature will require much more energy to cool the air within the data center and may cause equipment malfunction or breakdown.



# PROOF IS IN THE DATA

**Figure 5:** Computer modeling of standard six-inch racks with Cisco Catalyst 6509 switches

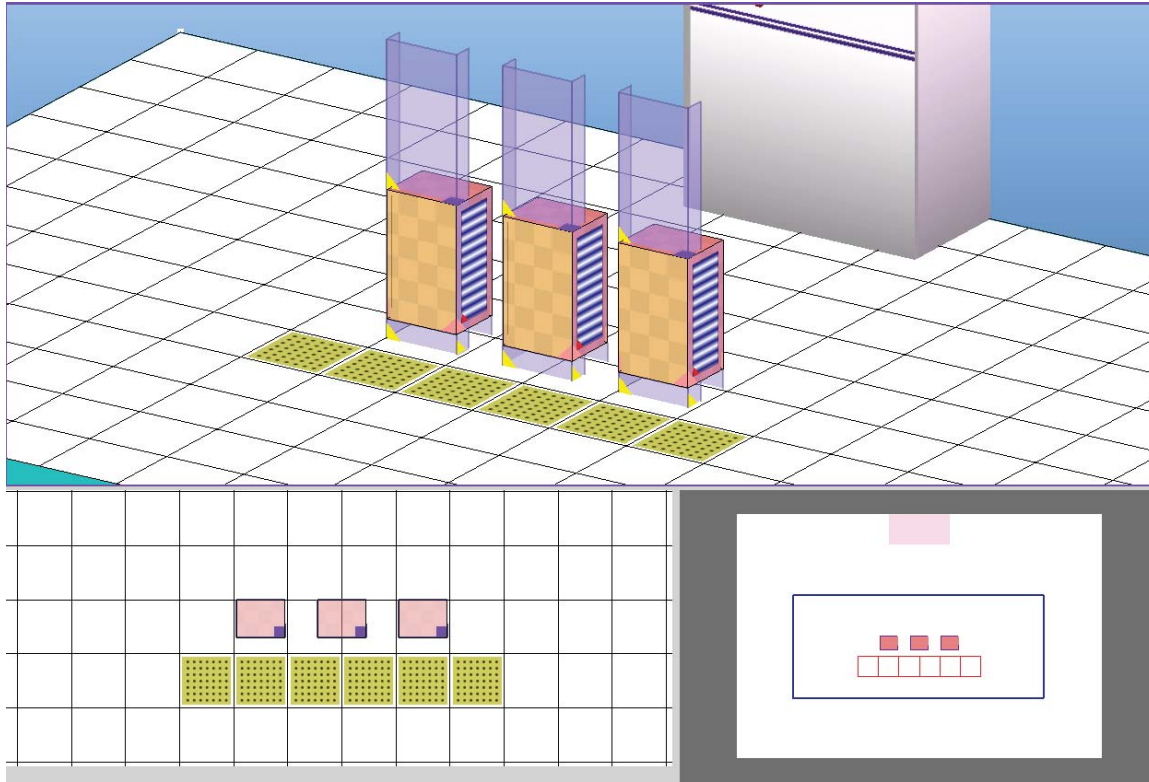

**Figure 6:** Thermal imaging plot of standard six-inch racks with Cisco Catalyst 6509 switches

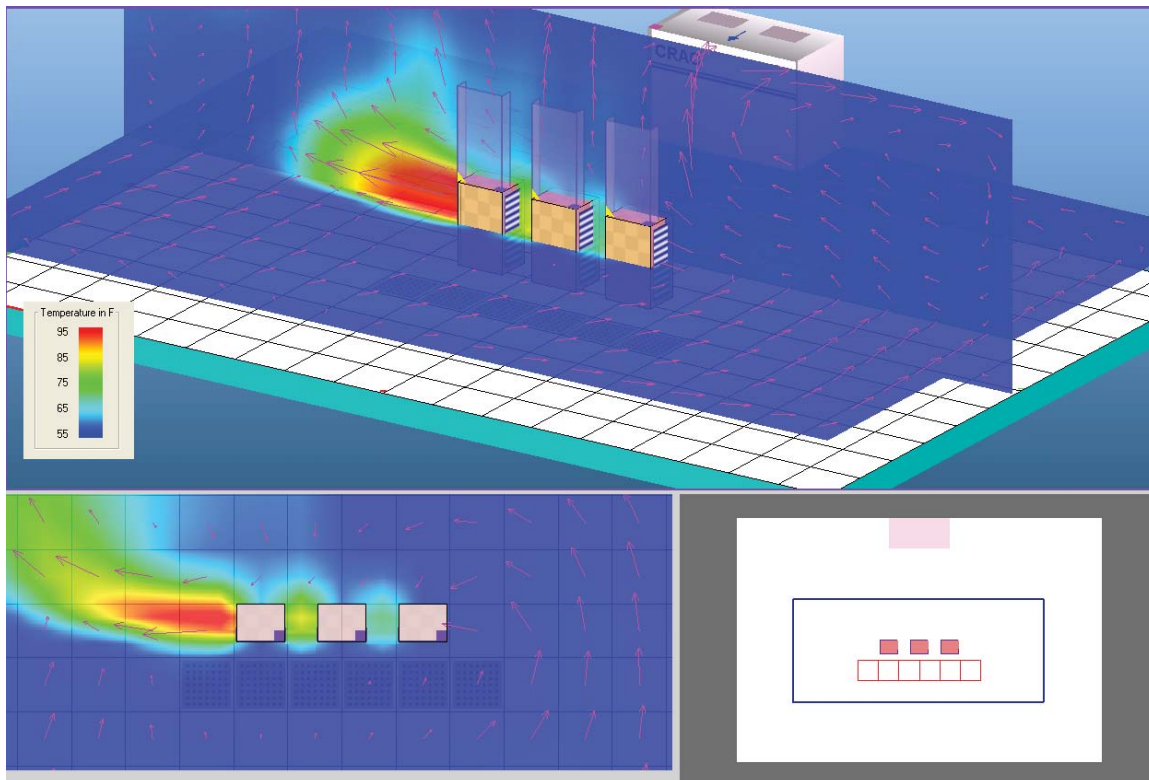

# CONCLUSION

The communication, computing, networking and data storage equipment installed in today's data centers requires that cable management and physical support systems be optimally designed to assure proper cooling. At a minimum, the cabling support equipment should not impede the proper airflow through the equipment so as to reduce efficiencies.

Through the proper selection of cable management racks, cabinets, and other necessary physical support products, the performance of the active electronic equipment used in data centers can be optimized for efficient performance, thereby reducing the overall operating costs and total cost of ownership (TOC).

Data center designers and consultants should carefully consider the design and proper type of equipment racks, cable management organizers and cabinets that are to be used with the specific switch and server equipment to be installed, so that optimum performance is assured now and into the future. Using proper cable, rack, and airflow management systems, the overall temperature in the data center can be lowered, resulting in energy savings, fewer equipment failures, and better system performance. Taking these simple steps toward environmental responsibility can have a significant impact on the overall performance of a data center and the efficiency of a business, as well as the environment.

# APPENDIX 1

Tests measured the temperature data at four different locations surrounding the equipment. Computer modeling displays the temperature values at the front and back of the rack, as well as the equipment intake and exhaust for both a standard racking installation and the Ortronics Mighty Mo 10 deep channel rack solution.

<b>Mighty Mo 10</b>				<b>Std EIA 6in</b>			
Temp in Front of Rack				Temp in Front of Rack			
Rack #	Min Temp (F)	Ave Temp (F)	Max Temp (F)	Rack #	Min Temp (F)	Ave Temp (F)	Max Temp (F)
1	55.0	55.1	55.1	1	55.0	56.8	58.5
2	55.0	56.0	56.9	2	55.1	58.2	61.3
3	55.0	57.2	59.3	3	55.2	59.4	63.6
Temp in Back of Rack				Temp in Back of Rack			
Rack #	Min Temp (F)	Ave Temp (F)	Max Temp (F)	Rack #	Min Temp (F)	Ave Temp (F)	Max Temp (F)
1	55.0	58.0	60.9	1	55.1	57.4	59.7
2	61.2	64.7	68.1	2	56.7	61.3	65.8
3	67.1	72.6	78.1	3	58.0	64.2	70.4
Temp at switch inlet				Temp at switch inlet			
Rack #	Min Temp (F)	Ave Temp (F)	Max Temp (F)	Rack #	Min Temp (F)	Ave Temp (F)	Max Temp (F)
1	55.0	55.1	55.2	1	55.1	55.2	55.3
2	55.0	63.0	70.9	2	68.3	69.3	70.2
3	55.0	67.0	78.9	3	80.4	82.0	83.5
Temp at switch Outlet				Temp at switch Outlet			
Rack #	Min Temp (F)	Ave Temp (F)	Max Temp (F)	Rack #	Min Temp (F)	Ave Temp (F)	Max Temp (F)
1			70.9	1			71.0
2			78.9	2			85.2
3			83.0	3			98.1

# APPENDIX 1

**Figure 7:** Plot of average temperature at the switch inlet of each rack

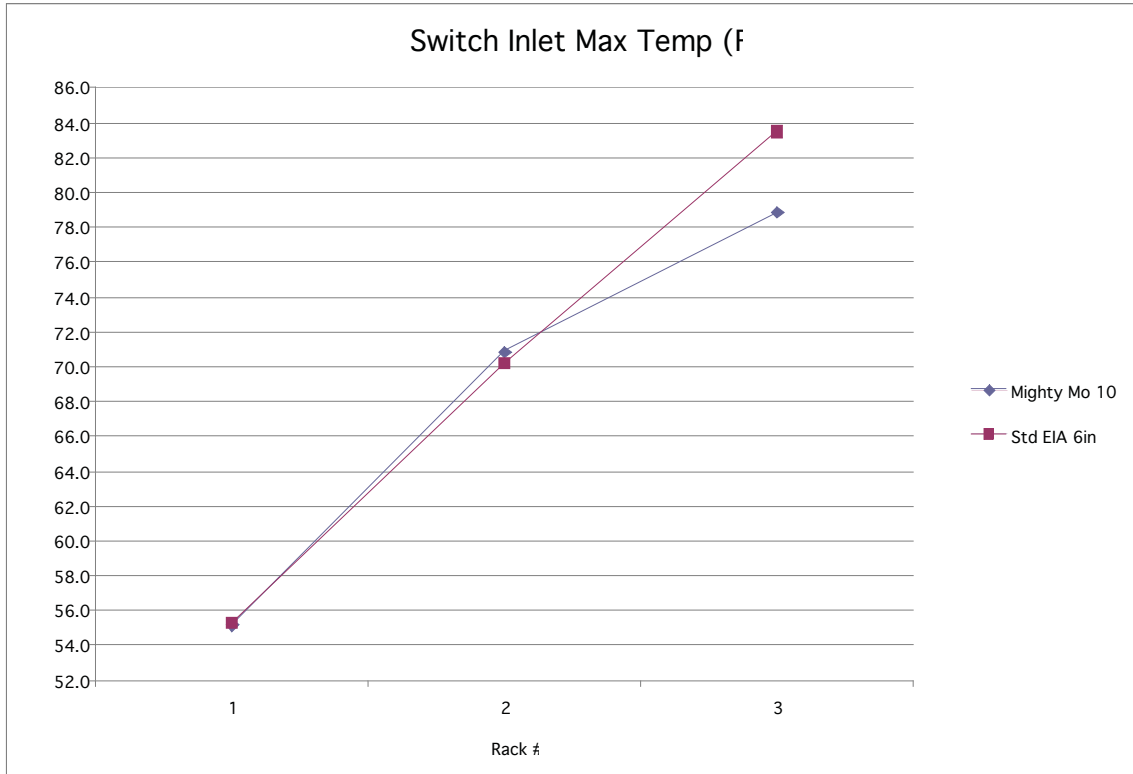

**Figure 8:** Plot of average temperature at the switch outlet of each rack

